

INSTRUCTIONS FOR OPERATION AND CARE OF

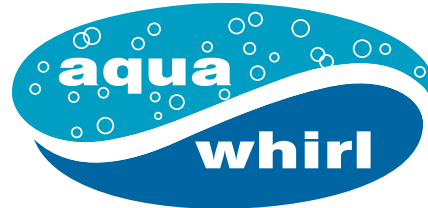
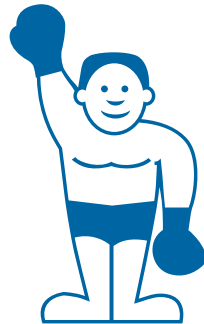

LITTLE

Champ

Compact Whirlpool

AW-606 & AW-607



Whitehall
Manufacturing[™]

800-782-7706 • 626-968-6681 • www.whitehallmfg.com

Member of  MORRIS GROUP
INTERNATIONAL



Introduction 3

Model Descriptions 3

Caution 4

Warning 4

Danger 4

Basic Set Up and Use Instructions 5

Cleaning and Sterilizing 5

Repair of Unit 5

Wiring Diagrams 6

Instructions for Operation and Care of Little Champ Compact Whirlpool



Congratulations on receiving your compact Little Champ Whirlpool.

The Little Champs turbine is designed for light duty but is long lasting when so utilized. The tanks are heavy-gage stainless steel, hand welded, and polished with a seamless covered bottom.

The turbines that are constructed for 110/120 volt usage are provided with a Ground Fault Circuit Interrupter for maximum electric protection.

The tank possesses a small rear drain for used water evacuated with no underneath cavity where water can remain.

Turbine water flow/ pressure is controlled by a variable speed control synchronized with the impeller drive motor.

Unit rating is 120V, 4.2A, 50/60Hz.



WARNING: The power cord for the whirlpool motor must only connect to the receptacle located in the tank.



Instructions for Operation and Care of Little Champ Compact Whirlpool

The instructions below are indicated by specific symbols. An understanding of these symbols, their companion text and the specific instructions and captions must be understood prior to operation of the equipment and patient treatment.



CAUTION- Ignoring the following could cause injury or equipment damage.



WARNING- These are safety infractions that could result in serious injury.

DANGER- These are possible safety infractions if this equipment is used where oxygen or flammable anesthetics are present.



CAUTION

- All internal parts capable of transmitting electric current are grounded. Therefore, the electrical outlet to which the unit is attached must be properly grounded. Grounding reliability can only be achieved when the equipment is connected to an equivalent receptacle marked "Hospital Only" or "Hospital Grade". The unit is provided with a GFCI plug on the power cord. If there is any question as to the electrical protection, a qualified electrician should be consulted.
- The table or floor must be level for proper and safe use.
- Little Champ Whirlpools are intended for use only where the person utilizing the treatment is under the supervision of trained personnel.
- **DO NOT** operate the turbine dry – always make sure the impeller housing is covered with water for proper lubrication.
- Always disconnect the line cord plug from the receptacle before working on any unit.
- Treatment temperature must be monitored closely and, of course, a patient's medical history must be reviewed, as with any heat modality, for heat sensitivity and circulatory problems.
- Do not use bleach or iodine based products to clean the tank as such products can quickly corrode the stainless steel tank resulting in pin holes and leaking water.



WARNING

- Do not touch cord or plug if you are wet, standing in water or on a wet surface.
 - Constant supervision is necessary when the unit is used with children, invalids, or any one who cannot safely operate the unit.
- The definition of such a patient is "a patient being treated with a externally electrically conductive device indwelling or implanted and terminating on or near the heart".
- Refer service and electrical problems to qualified personnel and/or Whitehall Manufacturing only.
 - Do not use if the unit, cord, or plug has been damaged. Return unit to Whitehall Manufacturing or a qualified service center.
 - Do not use an electrical extension cord. Plug unit directly into a properly grounded receptacle. If there is any question on the grounding of the receptacle, call an electrician.
 - If the turbine becomes immersed in water the GFCI is designed to activate and shut off current to the motor. If this should accidentally happen, thoroughly dry yourself, remove the patient from the whirlpool, and then thoroughly dry the patient and the floor before attempting to unplug the unit. Unplug the unit and then and only then remove the turbine from the water. Do not try to reset the GFCI. Return the unit to a qualified service center or Whitehall Manufacturing for inspection and repair with an explanation of what happened **DO NOT** attempt to service the unit yourself.
 - Again, do not defeat or alter the grounding means of the attachment plug and the power supply cord must be plugged into a properly wired and grounded hospital grade receptacle.

DANGER

- Do not operate any whirlpool where flammable anesthetics are present.



BASIC SET UP AND USE INSTRUCTIONS

- Carefully remove the turbine and make sure no packing obstructions are in the motor hood vents or pump housing outlet.
- Place tank on a level surface and place the turbine post at the drain end of the tank and secure the turbine firmly with the provided black knob.
- Test the GFCI operation by pressing the test button to make sure the reset button “pops out”.
- Close the drain valve by placing the rectangular knob in the vertical position.
- Fill the tank with water at desired temperature and as treated by local hygienic requirements.
- Adjust the turbine/impeller pump height relative to the tank bottom and water height by loosening and then tightening the lower knob.
- Plug the GFCI into the available grounded electric outlet and then turn the speed control to the lowest speed position (counter clockwise).
- Turn the switch on and increase the motor speed slowly to the desired water speed and volume.
- Again, test the GFCI. Push the test button on the GFCI- make sure the motor stops and then push the reset button. The unit is now operational.
- Again, do not operate the turbine without the impeller housing being completely covered with water.
- Finally, adjust the turbine height so as to place the impeller pump at the optimum treatment height.

CLEANING AND STERILIZING

Cleaning of the tanks can best be accomplished with a very mild, non-scratching household cleaner and a very low abrasion plastic scouring pad lightly applied. On a stainless steel tank, never use a metal scouring pad as it is too abrasive and may leave carbon metal deposits on the stainless which will rust.

Again, disinfection and sterilizing is different from facility to facility, and we have found that alcohol is still the best (but expensive) cleaning and sterilizing solution. Bleaches and/ or iodine should not be used, but if they are – if they must be – that thorough rinsing of all metal parts be accomplished. Never should bleach or iodine be allowed to “soak” on the surface of stainless steel without the solution being immediately washed completely off.

Initial evidence of excessive bleach and/or iodine use or lack of thorough rinsing will be the dulling and brassy appearance of the polished chromium plated turbine tubes.

Continued use of such practices will result in pin holes in the stainless steel tank and leaking.

It might be necessary at times to remove the bottom water inlet plate for cleaning of the impeller and interior of the pump housing. This can be accomplished by removing the screws underneath attaching the water inlet plate.

The turbine’s motor cover can be cleaned with a mild soap solution or a cleaner such as “Fantastic”. But making sure no liquid enters the ventilating holes so as to damage the turbines’ motor. Make sure the turbine is not plugged in during cleaning.

Your Little Champ turbine and/or tank has been manufactured with extreme care, thoroughly tested and is warranted against all defects in workmanship and is warranted against all defects in workmanship or material for a period of 1 year from date of shipment from the factory.

In hard water areas this warranty is dependent on the use of proper water softener to counter the harmful effects of mineral properties contained in the hard water. This warranty is not effective against conditions resulting from accidents, abuse, alterations or misuse.

Also, the warranty is not effective if the turbine has been run “dry” in the absence of lubricating water around and over the pump/impeller housing.

REPAIR OF UNIT

It may be necessary or you may desire to return the Little Champ unit for service. In that case, we would appreciate you contacting Whitehall Manufacturing directly. We will make arrangements for the unit to be returned to our production location. When the unit is received by us, an estimate of repairs will be made and you will be contacted. **Please- we appreciate warranty repair or any other repair be arranged directly with Whitehall Manufacturing. If you are not satisfied with our service, then and only then, contact your dealer.**



Instructions for Operation and Care of Little Champ Compact Whirlpool

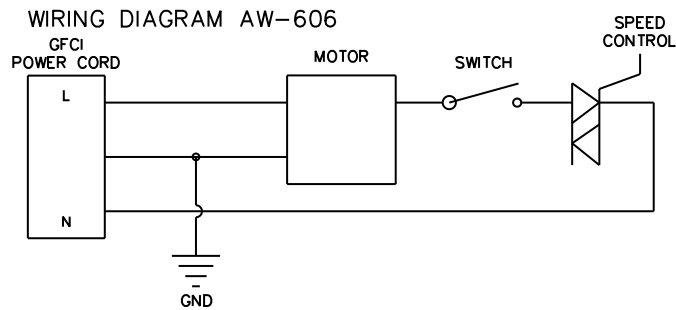
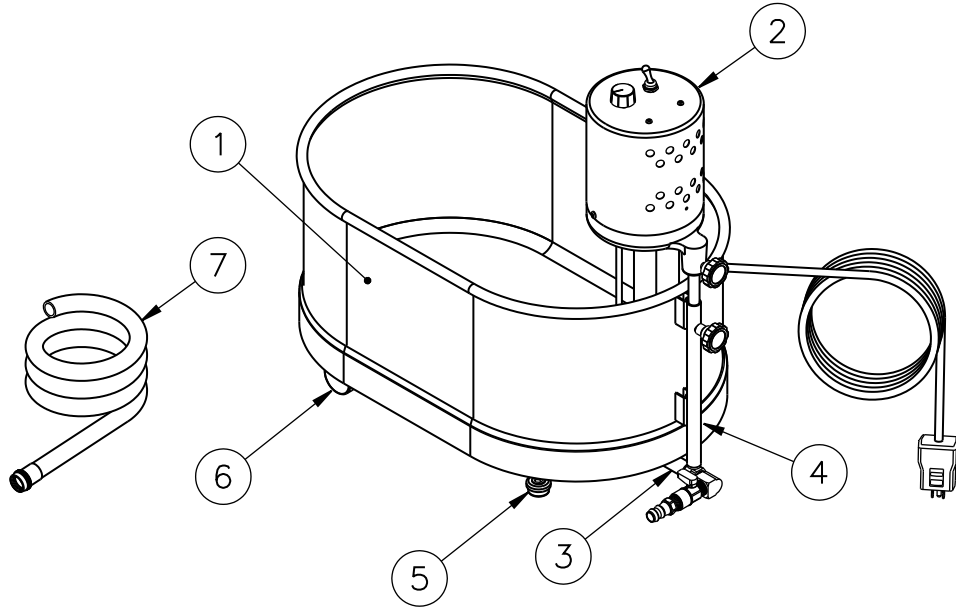

Whitehall Part #	Description
1	6560-100-003 Little Champ Tub Weld Assembly, AW-606
2	6560-000-001 AW-606 Turbine Assembly
3	6560-100-005 Little Champ Drain Assembly
4	6560-100-006 Little Champ R & L Tube Assembly
5	6560-121-000 Glide- Leveling
6	6560-120-000 Caster
7	6560-026-199 Hose- Filler, 4 Feet Long

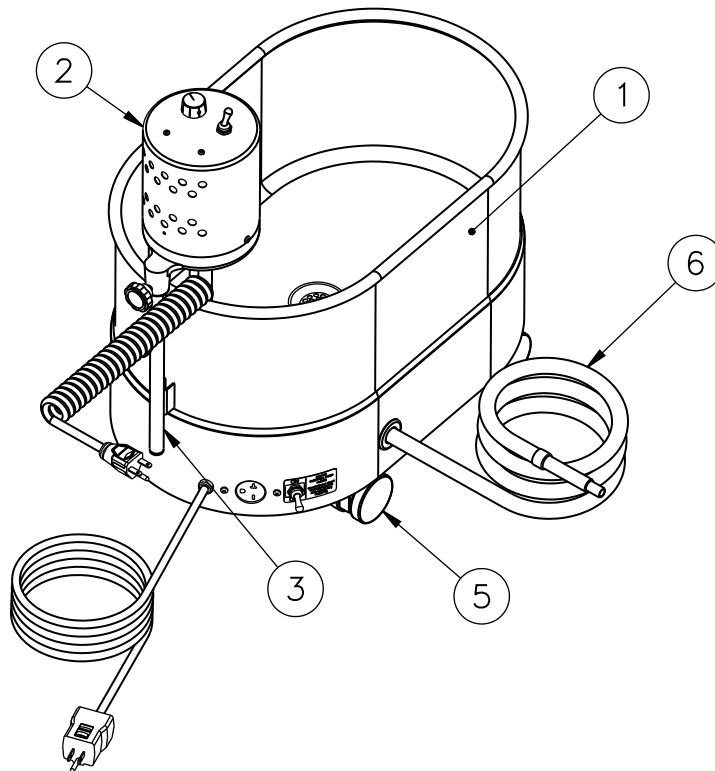

WIRING DIAGRAM AW-607

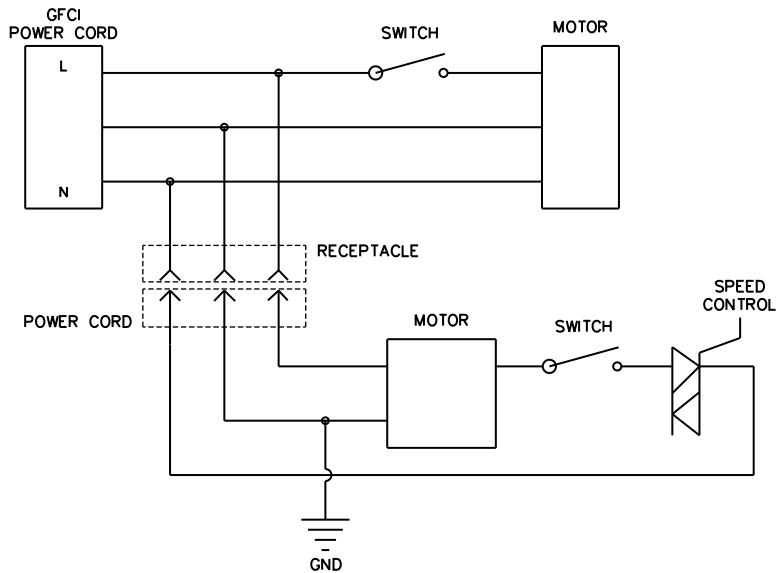

Whitehall Part #	Description
1	6561-100-004 Little Champ SDP Tub Weld Assembly, AW-607
2	6561-000-001 AW-607 Turbine Assembly
3	6560-100-006 Little Champ R & L Tube Assembly
4	6561-121-000 Motor, Drain 110V (Not Shown)
5	6561-128-000 Caster
6	6561-110-199 Little Champ SDP Evacuation Hose



Mailing Address:

P.O. Box 3527 • City of Industry, CA 91744-0527 U.S.A

Physical Address:

15125 Proctor Avenue • City of Industry, CA 91746 U.S.A

Phone 800-782-7706 • 626-968-6681

Fax 626-855-4862

Web: www.whitehallmfg.com

E-mail: info@whitehallmfg.com

Any questions regarding servicing of products in Europe or the Middle East should be directed to:
Niva Medical Company • Olarinluoma 14 B, FIN-02200 Espoo, Finland
Phone 358 9 615 00 540 • Fax 358 9 615 00 545
Web www.nivamedical.fi • E-mail info@nivamedical.fi

MANUFACTURER'S WARRANTY

Whitehall Manufacturing Company warrants that its products are free from defects in material or workmanship under normal use and service for a period of one year from date of shipment. Whitehall's liability under this warranty shall be discharged solely by replacement or repair of defective material, provided Whitehall is notified in writing within one year from date of shipment, F.O.B. Industry, California.

This warranty does not cover installation or labor charges, and does not apply to materials which have been damaged by other causes such as mishandling or improper care or abnormal use. The repair or replacement of the defective materials shall constitute the sole remedy of the Buyer and the sole remedy of Whitehall under this warranty. Whitehall shall not be liable under any circumstances for incidental, consequential or direct charges caused by defects in the materials, or any delay in the repair or replacement thereof. This warranty is in lieu of all other warranties expressed or implied. Product maintenance instructions are issued with each fixture, and disregard or non-compliance with these instructions will constitute an abnormal use condition and void the warranty. Stainless steel must be protected on jobsites during construction and must be properly maintained after the water has been introduced into the fixture, or Whitehall's limited warranty is void. If you have any questions or require technical assistance, please call 800-743-8219.

NOTICE TO KEEP ORIGINAL PACKAGING- Regarding warranty claims: customer must retain original packaging for one year upon receipt of product. If packaging is discarded, it is the customer's responsibility to provide adequate packaging. Any shipping claims that are a direct result of customer-provided packaging materials will be handled by the shipper.